



Yacht Club Uruguayo



## SAILING INSTRUCTIONS

SNIFE CLASS INTERNATIONAL RACING ASSOCIATION

### South American Championship 2023

April 5 to 9, 2023

Yacht Club Uruguayo

Montevideo

Amendment N 1

Rule number 4.4 and 24

Amendment N2

Rule Number 19.1 & 25.1

Amendment N3

Point 5.1

Amendment N4

Point 17.2

Amendment N5

Point 17.16

#### Notation [NP]

The notation [NP] in a rule in the SI means that a breach of this rule shall not be grounds for a protest by a boat.

#### Notation [SP]

The notation [SP] denotes a rule for which a standard penalty may be applied by the race committee without a hearing (this changes RRS A5); or a discretionary penalty applied by the International Jury with a hearing. This changes RRS 63.1, RRS a.5.1 and RRS A5.2.

#### Notation [DP]

The notation [DP] in a rule in the SI means that for a breach of this rule a discretionary penalty may be applied.

### 1 RULES

- 1.1 The regatta will be governed by the rules as defined in *The Racing Rules of Sailing*.
- 1.2 No National prescription will apply.
- 1.3 The SCIRA Rules of Conduct for Conducting National and International Championship will apply. Any conflict arising between the Deed of Gift and the SCIRA Rules of Conduct shall be solved by the application of the Rules of Conduct.
- 1.4 In case of conflict between the Notice of Race and the Sailing Instructions the Sailing Instructions shall prevail, this modifies RRS 63.7.
- 1.5 If there is a conflict between languages the English version text will take precedence.

### 2 NOTICES TO COMPETITORS

Notices to competitors will be posted on the Official Notice Board (ONB) which will be online at the following web: <https://ycu.roms.ar>.

### 3 CHANGES TO SAILING INSTRUCTIONS

- 3.1 Any change to the sailing instructions will be posted before 09.00 AM on the day it will take effect, except that any change to the schedule of races will be posted by 21.00 PM on the day before it will take effect.
- 3.2 Any change or amendment to the Sailing Instructions shall be approved with the SCIRA Representative.

### 4 SIGNALS MADE ASHORE

- 4.1 Signals made ashore will be displayed at the topmast near the ramp.
- 4.2 When the "AP" race signal is displayed ashore, '1 minute' is replaced with 'not less than 60 minutes' in the race signal "AP".
- 4.3 [NP] [DP]. When the "AP over H" race signal is displayed ashore, the boats shall not leave the harbour. The warning signal will be exposed no less than 60 minutes after the signal is lowered with one sound
- 4.4 [DP] Flag D with one sound means "Boats shall not leave the shore until this signal is made. The warning signal will not be made before the scheduled time or less than 60 minutes after the flag D is displayed."

### 5 SCHEDULE OF RACES

- 5.1 Dates of racing:

<u>Date</u>	<u>Time of Warning</u>	<u>Signal</u>
April 5	14.00	<b>Practice race</b>
	18.00	<b>Opening Ceremony</b>
April 6	09.30	<b>Sailor's Meeting</b>
	12.00	<b>Racing</b>
April 7	12.00	<b>Racing</b>
April 8	12.00	<b>Racing</b>
April 9	10.00	<b>Racing</b>

- 5.2 The regatta shall consist of 8 races.
- 5.3 No more than two (2) races shall be sailed per day; three (3) races can be sailed only if behind schedule.
- 5.4 In case of a prolonged postponement, to alert boats that a race or sequence of races will begin soon, an orange flag will be displayed with one sound for at least five minutes before a warning signal is made. Failures to observe this instruction are not grounds for redress.
- 5.5 On the last day of racing no warning signal will be made after 15.00.
- 5.6 There will be a competitors meeting on April 6, at 09.30 am near the "Sector náutico" and announced by two short whistles.

### 6 CLASS FLAGS

The official Class Flag shall be the Snipe Class flag, a red Snipe on a white background.

### 7 RACING AREAS

The Racing Area location is near the Yacht Club Uruguayo.

### 8 WEATHER LIMITATION (Course and Starting)

The wind speed ranges shall be in accordance with the SCIRA Rules of Conduct for Conducting National and International Championships and the applicable Deed of Gift.

### 9 THE COURSES

- 9.1 The diagrams below show the courses, including the approximate angles between legs, the order in which marks are to be passed. All course marks (except gates) shall be left to port.

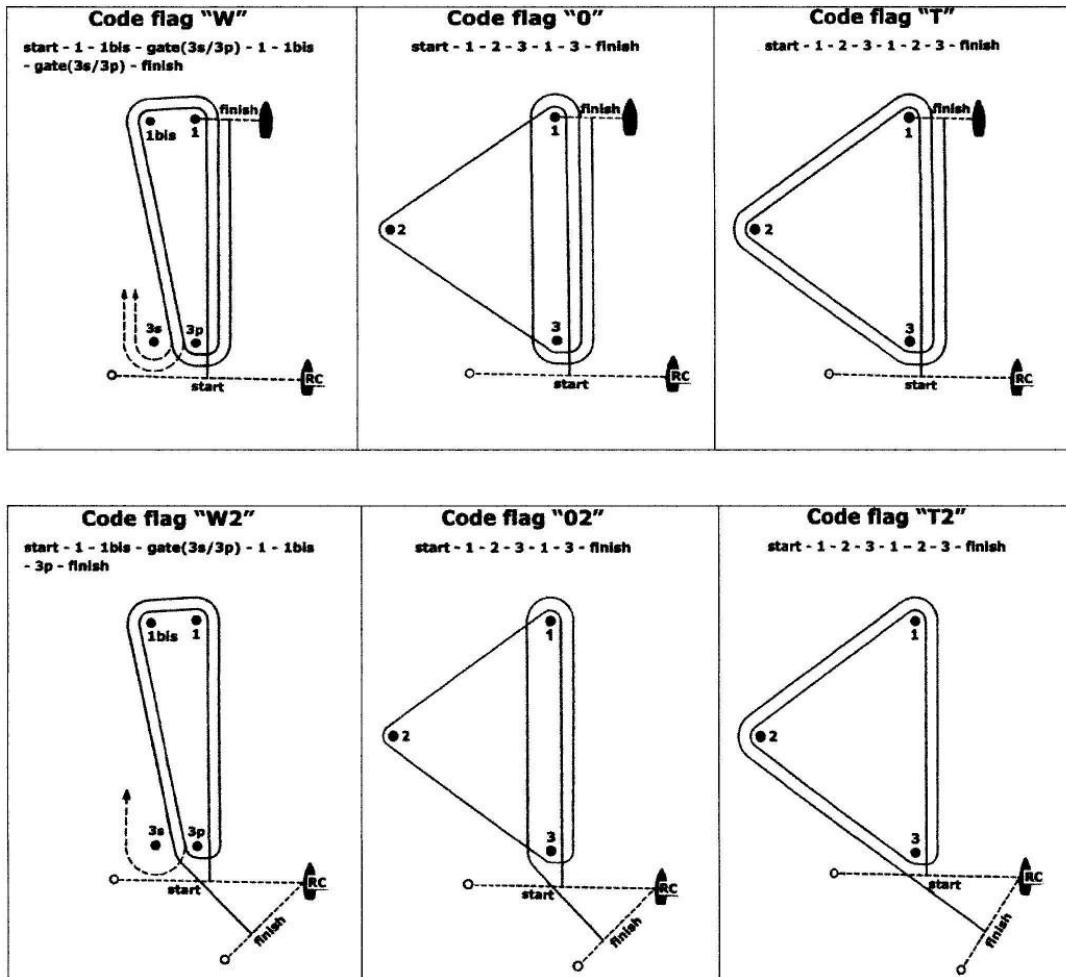

- 9.2 The course signal (code flag "W", "T", "O", "W2", "T2" or "O2") shall be hoisted with one sound at/or before last one minute before the warning signal. It will remain displayed for not less than five minutes after the start. This changes RRV 27.1
- 9.3 No later than the warning signal, the Race Committee signal boat will display the approximate compass bearing of the first leg.
- 9.4 If during a race the wind and/or wave action changes to the point where the selected course would be inadvisable (See Course Selection Diagram), the Race Committee shall change the course at any mark. A change of the type of course during the race shall be signalled displaying the new appropriate flag and accompanied by repetitive sounds before the leading boat has passed or rounded the mark. This changes RRV 27.1
- 9.5 A sustained wind variation of 20 degrees or more from the posted bearing during the first leg of a race shall result in the race to be abandoned and re-sailed, or abandoned. This changes the RRS 32.1.
- 9.6 A sustained wind variation of 40 degrees or more from the posted bearing during the first lap shall result in the race being abandoned and re-sailed, or abandoned. For the purpose of this rule a lap means the rounding of mark 3 (or passing the gate 3s-3p) for the first time. This changes the RRS 32.1.
- 9.7 The number of legs in a race may be reduced (RRS code flag S) but at least 2 (two) windward legs of the race shall be completed. This changes the RRS 32.2. [\*The SCIRA Representative shall be consulted.\*]

## 10 MARKS

- 10.1 Marks 1, 1bis, 2, 3, 3s and 3p will be cylindrical and orange.
- 10.2 New marks, as provided in instruction 13.1, will be cylindrical and yellow.
- 10.3 The port-end starting mark will be:
- a boat with an orange flag displayed;
  - an inflatable rubber buoy small cylindrical and yellow.
- 10.4 The finishing mark will be:
- mark 1 for "W", "O", and "T" courses;
  - a boat with an orange flag displayed;
  - an inflatable rubber buoy small cylindrical yellow buoy for "W2", "O2", and "T2" courses
- 10.5 A Race Committee vessel signalling a change of a leg of the course is a mark as provided in SI 13.2.

10.6 If one of the marks "gate 3s-3p" is not placed, or is not replaced as per RRS 34, the remaining mark shall be left to port. This changes the RRS 34.

## 11 BLANK

## 12 THE START

12.1 RRS 30.4 ('Black Flag Rule') shall be used after the second general recall.

12.2 The starting line will be between a staff displaying an orange flag on the Race Committee vessel at the starboard end and:

a) a staff displaying an orange flag on the starting mark as provided in instruction 10.3 a).

b) the course side of the starting mark as provided in instruction 10.3 b).

12.3 A boat starting later than 4 minutes after her starting signal will be scored Did Not Start without a hearing. This changes Appendices A4 and A5.

12.4 The Race Committee, after the finish of a race and before the warning signal of a subsequent one, will do its best to post on the Race Committee vessel a list of OCS, UFD or BFD boats. The failure of posting or an incomplete or wrong list will not be grounds for redress. This changes the RRS 62.1(a).

## 13 CHANGE OF THE NEXT LEG OF THE COURSE

13.1 To change the next leg of the course, the Race Committee will lay a new mark (or move the finishing line) and remove the original mark as soon as practicable. When in a subsequent change a new mark is replaced, it will be replaced by an original mark. It will be in accordance with the RRS 33 except point 13.3 of the sailing instructions.

13.2 Except at a gate, boats shall pass between the race committee boat signalling the change of the next leg and the nearby mark, leaving the mark to port and the Race Committee vessel starboard. This changes the RRS 28.

13.3 After the completion of the first windward leg of the race the remaining legs may be increased or decreased by not more than 30% of the original length. This changes the RRS 33). [\*The SCIRA Representative shall be consulted on any change of course which affects its length.\*]

13.4 If Mark 1 will be changed in courses "W" or "W2", Mark 1bis (offset) will no longer be a course mark.

## 14 THE FINISH

14.1 The finish line will be between a staff displaying a blue flag on the Race Committee vessel and the course side of the finishing mark *OR* another staff displaying a blue flag 10.4.

14.2 The A flag on the Race Committee boat at the finish means that there will be no more races for the day.

## 15 PENALTY SYSTEM

Appendix P will apply.

## 16 TIME LIMITS AND TARGET TIMES

16.1 The races will be managed to last 60-75 minutes for the first boat to finish. A different time (shorter or longer) used to complete the race will not be ground for requesting redress.

16.2 The time limit for the first boat to complete the first lap is 40 minutes from the start. If the first boat fails to complete the first lap within 40 minutes the Race Committee shall abandon the race. For the purpose of this rule a lap means the rounding of Mark 3 (or passing the Gate 3s/3p) for the first time.

16.3 The time limit for the first boat to finish the race shall be 1 hour, 30 minutes. Any boat finishing more than 20 minutes after the first boat finishes or failing to finish within 1 hour and 50 minutes from the start, whichever is shorter shall be scored Did Not Finish (DNF). This changes RRS 35, A4 and A5.

## 17 PROTESTS AND REQUESTS FOR REDRESS

17.1 Hearing request shall be delivered at the ONB. Protests and requests for redress or reopening shall be delivered at the ONB before the appropriate time limit.

17.2 **The protest time limit is 60 minutes after the last boat has finished the last race of the day or the Race Committee signals no more racing today, whichever is later.**

17.3 A request for redress based on an incident identified in a scoring enquiry will meet the time limit if:

(a) the scoring enquiry was delivered within the time limit specified in RRS 62.2 as changed by SI 17.3; and

(b) the request for redress is delivered as soon as reasonably possible after being notified of the race committee's response to the scoring enquiry. The response by the race committee may be notified in writing or through the online system (ONB) This changes RRS 62.2.

- 17.4 Notices will be posted no later than 30 minutes after the protest time limit to inform competitors of hearings in which they are parties or named as witnesses. Hearings will be held in the protest room, located at 4th floor, beginning at the time posted. Hearings may be scheduled to begin up to 30 minutes before the protest time limit.
- 17.5 Notices of protests by the Race Committee, Technical Committee or Protest Committee will be posted to inform boats under RRS 61.1(b).
- 17.6 A list of boats that have been penalized for breaking RRS 42 will be posted on the Official Notice Board (ONB).
- 17.7 A list of boats that have been penalized for breaking RRS 29.1(OCS) or 30.1(OCS) or 30.3(UFD) and 30.4 (BFD) will be posted on the Official Notice Board (ONB).
- 17.8 Breaches of rules in the SI marked with [NP] and NoR 3.4 (bow numbers) will not be grounds for a protest by a boat. This changes the RRS 60.1(a).
- 17.9 The penalty for breaking rules in the SI marked with [SP] and NoR 2.2 (bow numbers) may be applied at the discretion of the Race Committee, without a hearing, and shall be the 5% scoring penalty for nearest race completed by the infringing boat but not worse than the number of points corresponding to DSQ. This changes the RRS 63.1 and the App.A5.
- 17.10 Penalties for breaking Class Rules may be less than disqualification.
- 17.11 A list of boats that have been penalized as per SI 17.9 will be posted on the Official Notice Board.
- 17.12 An International Jury is constituted and shall have authority per RRS Appendix N. Their decision shall be final as provided in RRS 70.5. Per Appendix N2.2, SCIRA reserves for itself the right and responsibility to decide issues of eligibility, measurement and equipment. SCIRA may refer any issue to the International Jury for advice.
- 17.13 The use of team racing tactics shall not be tolerated.
- 17.14 For the purpose of RRS 64.4(b) the “authority responsible” is the Measurer of the event.
- 17.15 The Jury will abandon the race if, during a redress hearing, they conclude that the Race Committee did not follow Sailing Instructions 8, 9.5, 9.6, 9.7, and 13.3. This changes the RRS 64.3.
- 17.16 **On the last scheduled race day, result enquiries shall be delivered within 30 minutes after results are published. This modifies RRS 62.2**

## 18 SCORING

- 18.1 3 races are required to be completed to constitute a series.
- 18.2 (a) When fewer than 5 races have been completed, a boat’s series score will be the total of her race scores.
- (b) When from 5 to 8 races have been completed, a boat’s series score will be the total of her race scores excluding her worst score.
- 18.3 To request a correction of an alleged error in posted race or series results, a boat shall complete and submit a scoring enquiry available in the ONB.

## 19 [NP][SP][DP] SAFETY REGULATIONS

- 19.1 Check-Out and Check-In: Either the skipper or the crew have to sign a form located near the ramp, prior to them going to the water and once the races for the day are finished and they are back on land ~~and also in the championship web.~~
- 19.2 A boat that retires from a race (RET) shall notify the Race Committee as soon as possible. The boat shall complete a retirement declaration form at ONB site. <https://ycu.roms.ar/snipesa2023/index.php/en/>

## 20 REPLACEMENT OF CREW OR EQUIPMENT

- 20.1 The same crew shall race in all races, except for reasons satisfactory to the Race Committee. Requests for a change of crew shall be submitted by the ONB to the Technical committee (TC). Once a crew has been excused, he/she may not return for the balance of the series. The TC shall reply to the request on the ONB.
- 20.2 The same skipper shall sail all races and can be replaced after the first race only, and then only if he/she is obviously incapacitated. If a skipper is replaced the first race shall be the race dropped, or scored DNC.
- 20.3 [DP] Substitution of damaged or lost equipment will not be allowed unless authorized by the Technical Committee. Requests for substitution shall be made to the Technical Committee at the first reasonable opportunity by the ONB The TC shall reply to the request on the ONB.

## 21 [NP] EQUIPMENT AND MEASUREMENT CHECKS

A boat or equipment may be inspected at any time for compliance with the Class Rules and Sailing Instructions. On the water, a boat can be instructed by a member of the Technical Committee, or the equipment inspector or measurer, to proceed immediately to a designated area for inspection.

22 [NP][SP] EVENT ADVERTISING

Boats shall display event advertising supplied by the organizing authority as follows: The number must always be nearest the bow



23 RIGHTS TO USE NAME AND LIKENESS

By participating in this event, competitors automatically grant to the SCIRA, organizing authority and the event sponsors the right, in perpetuity, to make, use, and show, at their discretion, any photography, audio and video recording, and other reproductions of them made at the venue or on the water from the time of their arrival at the venue, until their final departure, without compensation.

24 OFFICIAL BOATS

Official boats will be marked as follows: RC boat will have a White flag with CR in color Jury boats will have a black flag with JURY in white

25 [NP] [DP] SUPPORT BOATS

25.1 ~~Team leaders, coaches and other support personnel shall not go afloat in the racing area during the racing except upon Race Committee designated spectator boats. The Race Committee may initiate additional restrictions by posting them on the Official Notice Board.~~

25.2 At the preparatory signal, coaches must be positioned at least 50 meters below the starting line and their extensions. After the starting signal coaches may follow the fleet, but only on the port side of the course and must stay 50 meters from any mark and from any boat racing.

25.3 Coaches shall not communicate with competitors after the warning signal for any race until after the competitors have finished the race.

25.4 Coaches shall register at the Regatta Office and all support boats shall be identified with an orange or yellow flag with a number.

26 [DP] RADIO COMMUNICATIONS

A boat that is racing shall not make voice or data transmissions and shall not receive voice or data communication that is not available to all boats, except in an emergency or when using equipment provided by the race committee.

27 [DP] DRONES

No drones are allowed closer than 500 m from racing areas from the Warning Signal for a race and after the last boat has finished the race. As a penalty for breaching this rule the protest committee may impose a discretionary penalty (DP) to all boats associated with the owner / operator of the drone. This does not apply to OA drones.

28 [NP] [DP] TRASH DISPOSAL

Trash may be placed aboard support and Committee Vessels.

29 PRIZES

Prizes shall be awarded as provided by NoR.

Signatures:

**Kiko Kundig** - Race Committee Chairman

**Paola Prada** - SCIRA Representative

